

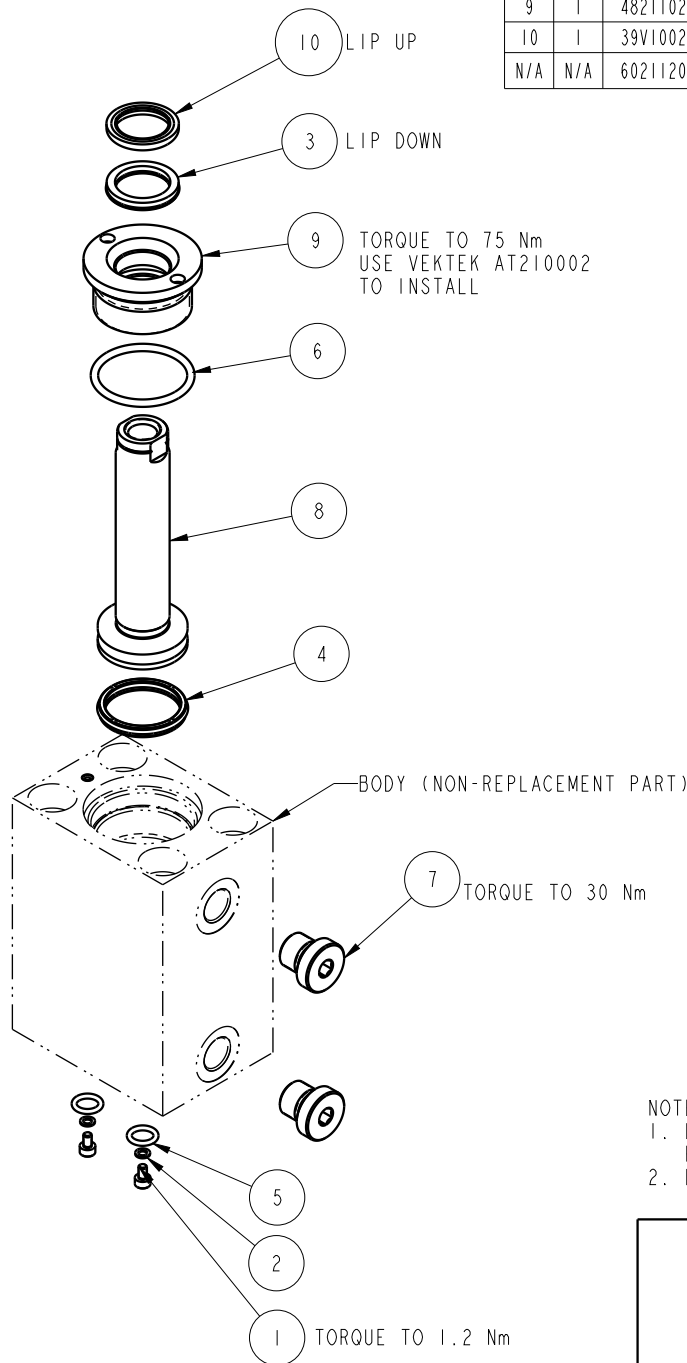

NO	QTY	PART NO	DESCRIPTION	STD SEAL KIT
1	2	21500018	SCREW, CAP, SOCH, M3 X 5, ALY	
2	2	21500200	WASHER	
3	1	39010021	SEAL, LL, (3/4 X 1/8 X 1/8 X 1)	X
4	1	39011030	SEAL, CROWN, 1-1/16x1-1/4x5/32	X
5	2	39050042	O-RING, (-011)	X
6	1	39051073	O-RING, (-124)	X
7	2	43068006	PLUG, PORT, HOLLOW HEX, G1/4	
8	1	48211015	PISTON, CYL, BB, COMBO, 27,7 KN, 50	
9	1	48211022	GLAND, CYL, BB, COMBO, 27,7 KN	
10	1	39V10022	WIPER, PRESS-IN, (3/4)	X
N/A	N/A	60211202	KIT, SEAL, CYL, BB, COMBO, DA, 27.7 KN	NOTED



- NOTES:
- LUBRICATE ALL SEALS WITH CLEAN HYDRAULIC FLUID PRIOR TO INSTALLATION.
  - DO NOT USE SILICONE TYPE LUBRICANTS.

<b>PARTS LIST</b>	 VEKTEK, INC. 1334 E. SIXTH AVE. P.O. BOX 625 EMPORIA, KS. 66801 U.S.A.
	ASSEMBLIES AFFECTED 42112105 L2112105
PARTS LIST, CYL, BB, COMBO, DA, 27.7 KN, 50 SIZE A <b>MPLV4205</b>	REV D SHEET 1 OF 1

D	4246	RELEASE	MJUST	8/4/20
REV	IN ACCORDANCE WITH ECN	EFFECTIVE DATE	REVISED BY	DATE
DRW BY:	K. ROEMER	<b>DRAWING STATUS: Released</b>		
DATE:	11/09/11	PRODUCTION APPROVED FOR RELEASED STATUS ONLY		